



Sensor Faucets and Flush Valves

H-8000C-B1DC

1.0 GPF

AC Powered Flush Valve w/ Battery Backup (Urinal)

Description

AC powered with battery backup, sensor operated, water conserving, urinal flush valve for floor mounted or wall hung top spud bowls.

Flush Cycle

- 1.0 GPF
 - * Flush valves may not function with all bowls. Be sure to verify flow requirements with bowl manufacturer.
 - * Flow rate is field adjustable

Specifications

Exposed, Piston Operated, Chrome Plated, Closet Flush Valve with the following features:

- Standard Brass/Chrome Plated All Metal Construction
- Superior, Slow-Closing, Piston Flushing Mechanism
- Standard Manual –Mechanical Override Button
- Field Adjustable to Left or Right Rough-In (additional part required)
- Operating Pressures: 10-125 PSI
- Standard Self-Cleaning Filtering System
- Superior VSI Silicone Elastomer Piston Seals are Unaffected by Chlorine, Chloramines, and Ammonia
- ADA Compliant—Infrared Sensor Operated for “No Hands” operation
- Self-Diagnostic Electronic System with Manual Reset
- Reliable, Latching Solenoid Valve
- Preset / Adjustable Sensor Distance
- Adjustable Tailpiece
- 3/4" I.P.S. Angle Stop Valve with Vandal Resistant Cap
- High Back Pressure Vacuum Breaker / Flush Tube Connection
- Spud Coupling and Flange for 3/4" Top Spud
- Sweat Solder Adapter with Cover Tube and Wall Flange
- High Copper, Low Zinc Brass Casting for Dezincification Resistance
- 36-hour Sentinel Flush
- Plug-In Power Adapter Furnished as Standard
- (4) AA Alkaline Batteries - Furnished

Electrical Specifications

- Plug-In Power Adapter
 - Input: 120V AC (60 Hz), Output: 12V DC
- Solenoid Valve and Sensor, 6V DC

Optional Accessories

- HC-010 Multi-Unit Power Adapter (Powers up to 8 flush valves)

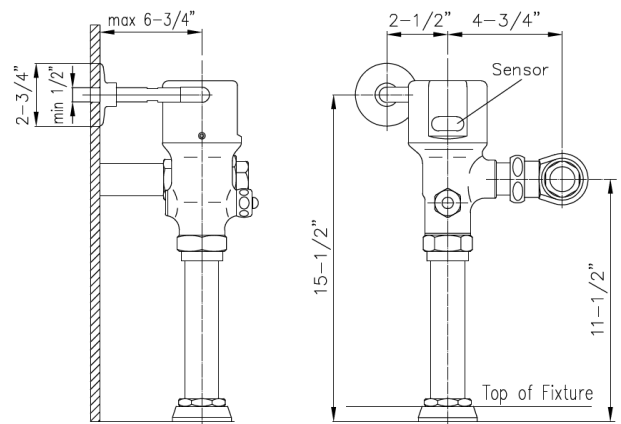

HYDROTEK INTERNATIONAL, INC.

5055 Forsyth Commerce Rd., Ste 124
Orlando, FL 32807

800.922.9883 (Phone)

866.670.5580 (Fax)

www.hydrotekintl.com

