



ISO 9001 Certified



OPERATION & MAINTENANCE MANUAL

HB-8000C Series Flush Valve

(includes HB8RFKC)

www.hydrotekintl.com

5055 Forsyth Commerce Rd, Ste 124, Orlando, FL 32807

Phone (800) 922-9883 | Fax (866) 670-5580



ISO 9001 Certified

8000 Series

U.S. Patent 6192530B1, 5699994

AC, Battery, or Solar Powered Sensor Operated Flush

The Hydrotek 8000 Series Automatic Flush Valves are the most advanced, electronic flushing system in the industry today. By incorporating our field-tested electronic circuitry and slow-closing solenoid valves, Hydrotek has developed an innovative non-diaphragm, piston flushing mechanism that will provide years of dependable and trouble-free service. The Hydrotek AUTOFLUSH system is completely automatic: there is no need to contact any surface, no handle to push, and it flushes only when it is used. It provides the ultimate sanitary protection, the convenience of cleaner restroom facilities, and the most efficient system in water conservation.

- **ADA Compliant.** Meets all barrier free codes
- Conserves water and energy
- Easily installed in new or retrofit applications
- Competitively priced for today's commercial market
- Promotes cleanliness & hygiene
- Proven Hydrotek craftsmanship and reliability

H-8000C Series (AC)
Complete Units



HB-8000C Series (Battery)
Complete Units



HB8RFKC Series (Battery)
Complete Units



HB-8000SLE Series (Solar)
Complete Units



Features:

- **ACCU-SENSE** adjustable sensor eyes
- Standard manual mechanical override button for both urinals & water closets
- Standard brass/chrome-plated, all metal construction with other finishes available
- AC/DC powered - field switchable
- Preset/adjustable flow rate and sensor distance
- Self-diagnostic electronics
- Standard vandal resistant stop valve (complete units only)
- Superior piston flushing mechanism
- Field adjustable for left and right rough-in
- Battery replacement without water shut-off
- Operating pressures: 10-125 PSI
- Standard self-cleaning filtering system
- Switchable from/to urinal or closet
- 36 hour sentinel flush
- Superior VSI silicone elastomer seals, unaffected by chlorine, chloramines or ammonia
- AC with DC backup models automatically switch to batteries during a power outage
- Uses inexpensive AA batteries
- Battery service life: 400,000 on/off cycles (650,000 for the HB-8000SLE Series)
- Low battery indicator light (battery powered only)
- No outside power source required (battery powered only)
- Can be installed by one tradesperson (battery powered only)

Hydrotek Autoflush Valves

8000 Series

Meets A.S.S.E. Standard 1037-89

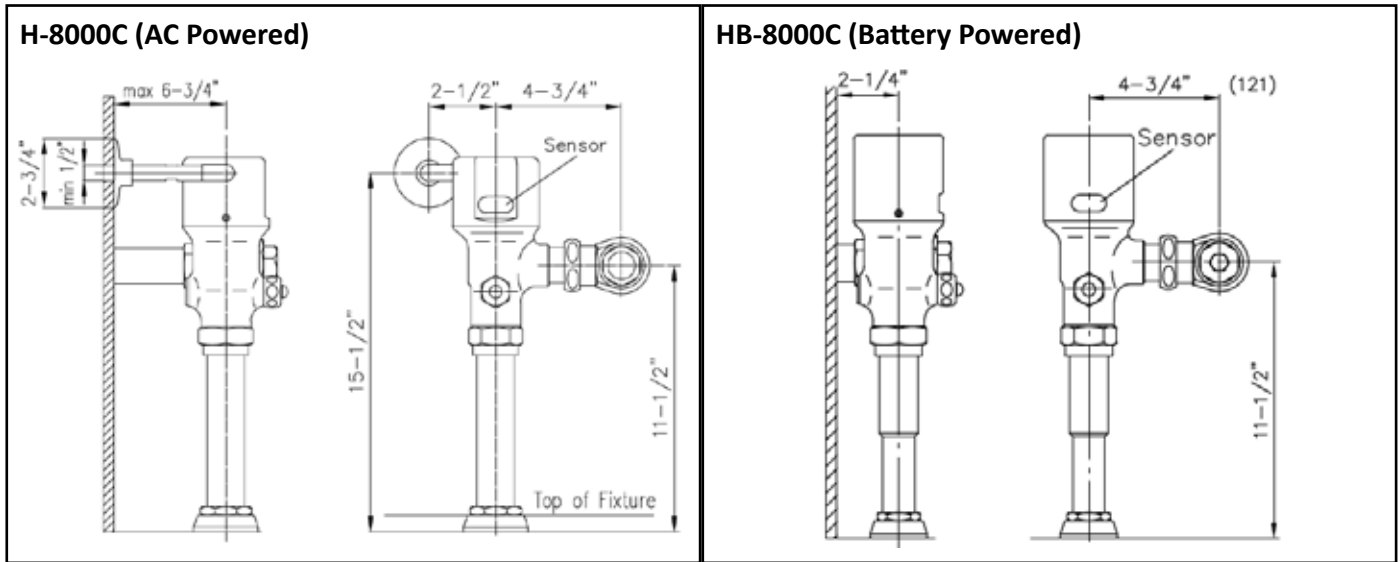

The 8000 Series Flush Valves are available in:

H-8000C Series (AC Powered):

- ✓ H-8000C-A (Closet)
- ✓ H-8000C-B1 (Urinal)
- ✓ H-8000C-B2 (Urinal)

Water conservation, concealed and AC with DC backup models available

HB-8000C Series (Battery Powered):

- ✓ HB-8000C-A (Closet)
- ✓ HB-8000C-B1 (Urinal)
- ✓ HB-8000C-B2 (Urinal)

Water conservation and concealed models available

HB-8000SLE Series (Solar Powered):

- ✓ HB-8000SLE-A (Closet)
- ✓ HB-8000SLE-B1 (Urinal)
- ✓ HB-8000SLE-B2 (Urinal)

Water conservation and retrofit models available

HB8RFKC Series Retrofit Models (Battery Powered):

Sloan & Zurn Retrofit

- ✓ HB8RFKC-C (Closet)
- ✓ HB8RFKC-U (Urinal)

Delany Retrofit

- ✓ HB8RFKC-CD (Closet)
- ✓ HB8RFKC-UD (Urinal)

Water conservation models available

HYDROTEK INTERNATIONAL, INC.

5055 Forsyth Commerce Rd., Ste 124

Orlando, FL 32807

800.922.9883 (Phone)

866.670.5580 (Fax)

www.hydrotekintl.com



PLUMBING SPECIFICATIONS:

Model	Fixture	Supply Line	Top Spud	Flow Rate
H/HB-8000C-A	Closet	1"	1-1/2"	1.6 GPF
H/HB-8-128	Closet	1"	1-1/2"	1.28 GPF
H/HB-8000C-B1	Urinal	3/4"	3/4"	1.0 GPF
H/HB-8000C-B2	Urinal	1"	1-1/4"	1.0 GPF
HB8RFKC-C/U	Cl. & Ur.	N/A	N/A	0.5-3.5 GPF

ELECTRICAL REQUIREMENTS:

- AC Powered Units:
 - Solenoid valve and sensor: 6V DC
 - Transformer: Input 120V AC, 60 Hz
Output 12V DC
- Battery Powered Units
 - Solenoid valve and sensor: 6V DC
 - Battery: (4) AA Alkaline Batteries
 - Battery Service Life:
 - o 400,000 flushes, up to 6 years (Battery)
 - o 650,000 flushes, up to 10 years (Solar)

BASIC PACKAGE INCLUDES:

	H-8000C (-A, -B1, -B2)	HB-8000C (-A, -B1, -B 2)	HB8RFKC (-C, -U)	HB-8000SLE (-A, -B1, -B2)
(1) Flush Valve	✓	✓	✓	✓
(1) Stop Valve	✓	✓		✓
(1) Sweat Kit	✓	✓		✓
(1) Flush Tube	✓	✓		✓
(1) Spud Coupling	✓	✓		✓
(1) Vacuum Breaker	✓	✓		✓
(1) AC Adapter	✓			
(1) AC Input Tube	✓			
(4) AA Batters		✓	✓	✓

OPTIONAL ACCESSORIES:

- HC-010 Multi-Unit Power Adapter (AC only) - 8 units
- HC-0104 Multi-Unit Power Adapter (AC only) - 4 units

HB-8000C

Solar Powered Flush Valve with Battery Backup Installation Instructions

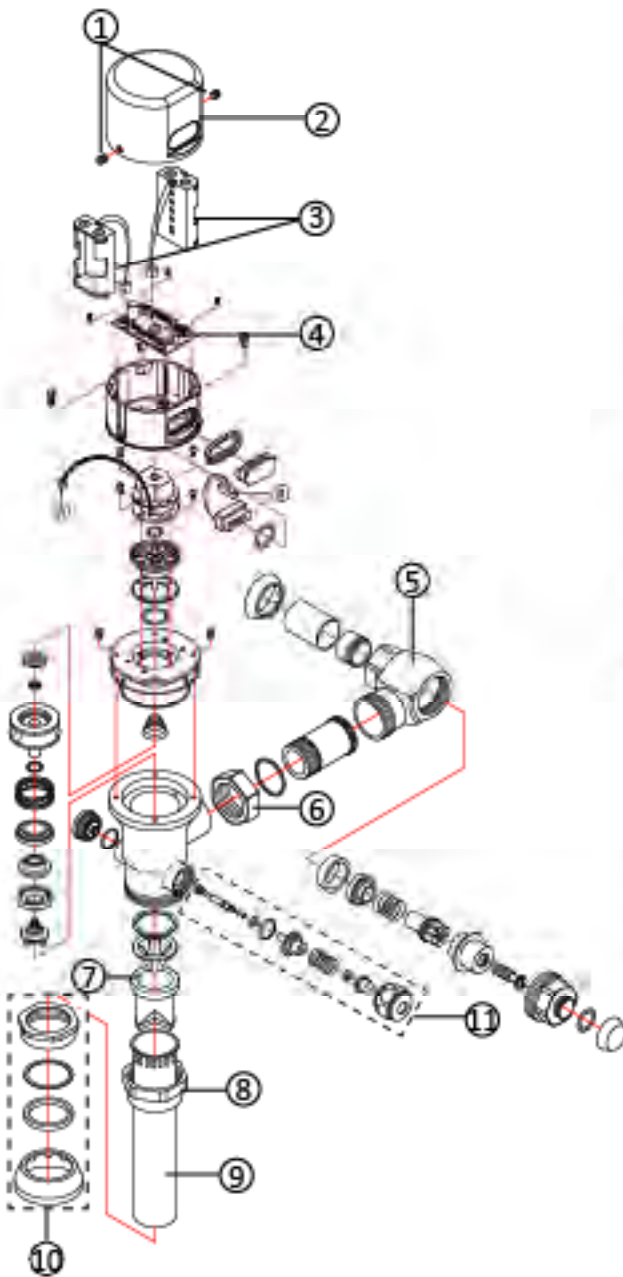

Installation Instructions:

1. Prior to installation, "DRY TEST" the unit for proper operations. Loosen the Set Screws (1) using the allen wrench provided and remove the Top Cap (2) from the valve body by pulling it straight up.
2. Properly insert 4 AA batteries into the Battery Holders (3). Push the RESET button and watch the indicator lights on the Control Module (4) for the following pattern: Red, (click), Green, Red, Red. This indicates that the electronics are functioning properly. If the indicator lights do not blink, contact the factory or your local Hydrotek representative.
3. Reinstall the Top Cap (2) onto the valve body and tighten the Set Screws (1). Install the Stop Valve (5) to the supply line using a Hydrotek Sweat Kit (optional).
4. Connect the valve body to the Stop Valve (5) using the Slip Joint Nut (6).
5. Attach the Vacuum Breaker (7) and Tailpiece (9) to the valve body using the Lock Nut (8). Secure the Tailpiece (9) to the plumbing fixture using the provided Spud Coupling (10).
6. Turn the water on through the Stop Valve (5) and check for leaks. Push and hold the Override Button (11) for 30 seconds and check the fixture for overflow. Adjust the water flow from the Stop Valve (5) for a smoother flush.
7. TEST: Stand in front of the flush valve for 4 seconds, then step away. The valve should flush automatically. If not, refer to the Troubleshooting Guide.
8. Flow rates are preadjusted from the factory. If minor adjustments are needed, contact Hydrotek for further details.

Parts:

- | | |
|-----------------------|---------------------|
| 1. Set Screws | 7. Vacuum Breaker |
| 2. Top Cap | 8. Lock Nut |
| 3. Battery Holder (2) | 9. Tailpiece |
| 4. Control Module | 10. Spud Coupling |
| 5. Angle Stop | 11. Override Button |
| 6. Slip Joint Nut | |

HYDROTEK INTERNATIONAL, INC.
5055 Forsyth Commerce Rd., Ste 124
Orlando, FL 32807
800.922.9883 (Phone)
866.670.5580 (Fax)
www.hydrotekintl.com



HB-8000C Series

Sensor Operated Flush Valve Troubleshooting Guide

Normal Operation: When power is connected, the flush valve will immediately perform diagnostic function. You will hear a clicking sound and see lights flash. When the sensor is activated, the light will flash once and the valve will flush. The red indicator light will flash when the batteries are low.

Problem	Possible Cause	To Diagnose	Remedy
Valve will not turn on:	Water not turned on	Check water supply	Turn water on
	Power supply failure	No light, no clicking: <ul style="list-style-type: none">• Check batteries• Check power adapter	Reinstall or replace batteries/ Replace power adapter
	Low battery	Light continues to flash	Replace batteries
	Electronic PCB / Sensor is defective	No light, no clicking: <ul style="list-style-type: none">• Reinsert batteries• Reattach power adapter	Replace electronic PCB
	Solenoid valve is clogged	Solenoid is clicking but no water is coming out	Clean solenoid
	Solenoid coil is defective	Insert new batteries or reattach power adapter. Light blinks but no solenoid is clicking	Replace solenoid coil
Valve will not shut off:	The solenoid valve is normally closed. Turn off water and activate the valve. If there is a clicking sound, the solenoid valve is dirty. If there is no clicking sound, then check the solenoid valve. If water is leaking through, the solenoid valve is dirty and needs to be serviced. Other factors include: <ul style="list-style-type: none">• Sensor distance is too long• Control module is defective• Manual override button is sticking		

IMPORTANT: Periodic maintenance is required for smooth and trouble-free operation of this flush valve.

For service and inquiry about available repair kits, please call Hydrotek Technical Support at (800) 922-9883.

HB-8000C Series

Sensor Operated Flush Valve

Assembly Parts

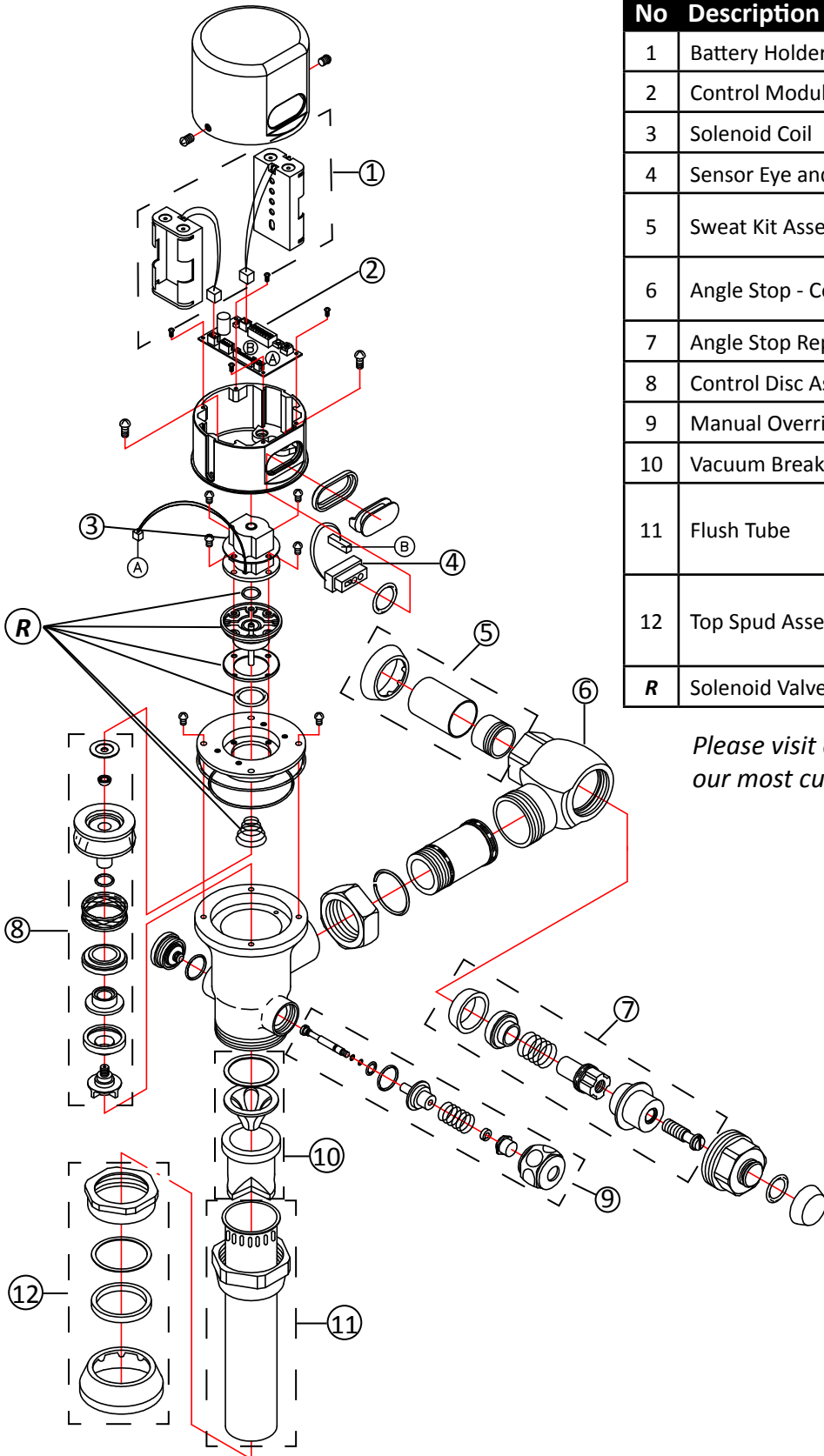

No	Description	Part Number
1	Battery Holders (2 required)	HCC-104A
2	Control Module	HCC-080B
3	Solenoid Coil	HCC-098
4	Sensor Eye and Cable	HCC-080E
5	Sweat Kit Assembly	HC-084 (3/4") HC-084B (1")
6	Angle Stop - Complete Assembly	HC-082A (3/4") HC-082B (1")
7	Angle Stop Repair Kit	HC-082C
8	Control Disc Assembly	HCC-102
9	Manual Override Button Assembly	HC-089
10	Vacuum Breaker Repair Kit	HC-086
11	Flush Tube	HC-086A (1-1/2") HC-086B (3/4") HC-086C (1-1/4")
12	Top Spud Assembly	HC-093A (3/4") HC-093B (1-1/4") HC-093C (1-1/2")
R	Solenoid Valve Repair Kit	HCC-106

Please visit our website, www.hydrotekintl.com, for our most current Products Pricing Sheet.

HB-8000C Series

Sensor Operated Flush Valve Control Module

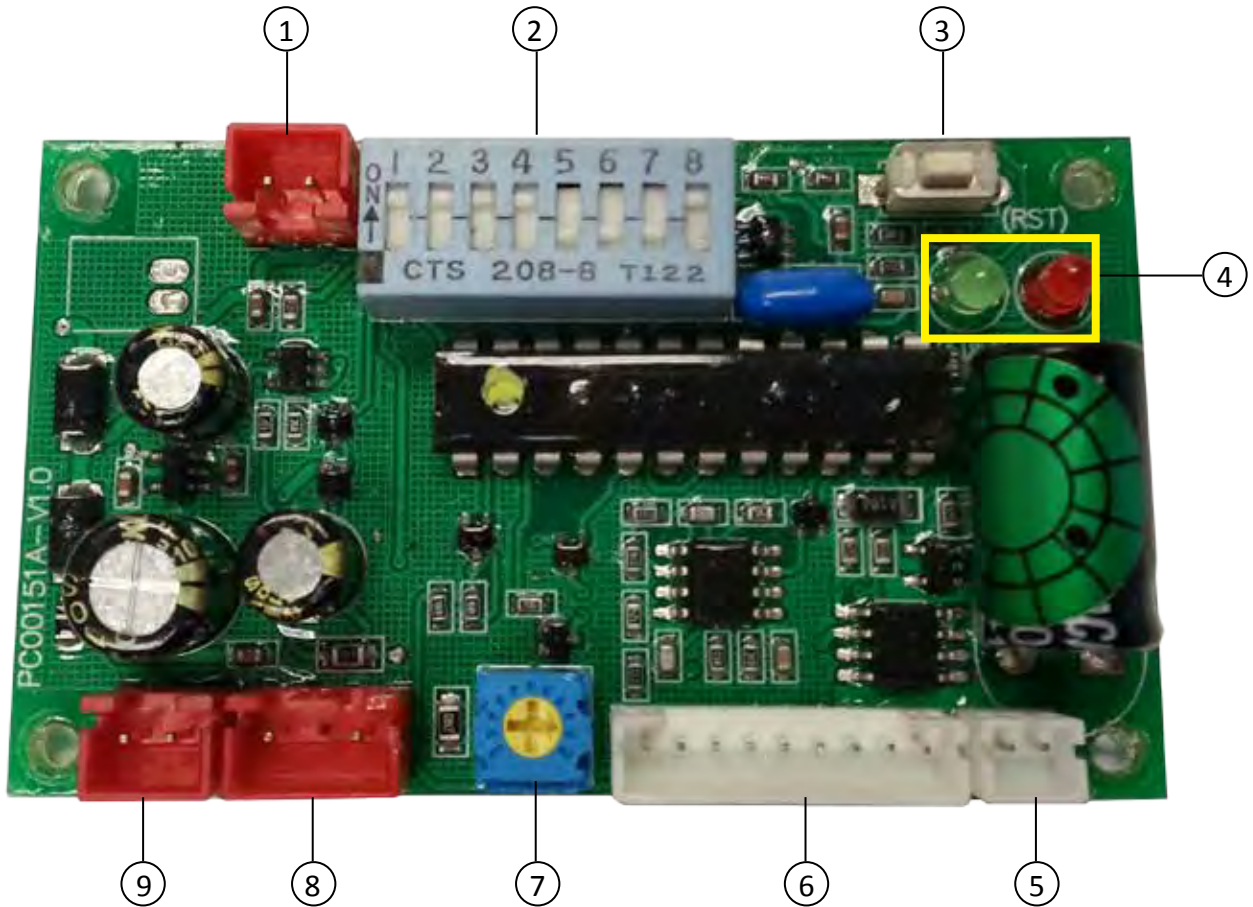

LEGEND

- | | |
|--------------------------|--|
| 1. DC Input Pin Receptor | 6. Control Cable (Sensor Eye) Pin Receptor |
| 2. Dip Switches | 7. Sensor Distance Adjustment Dial |
| 3. Reset Button | 8. AC Input Pin Receptor |
| 4. Indicator Lights | 9. DC Input Pin Receptor |
| 5. Solenoid Pin Receptor | |

HB-8000C Series

Sensor Operated Flush Valve Control Module Settings

Flow rate and sensor arming time can be adjusted via the dip switches located on the Control Module.

Flushing Volume

Urinal	0.125*	ON	ON	OFF	ON
	0.5	ON	ON	ON	ON
	1.0	ON	ON	ON	OFF
Closet	1.28	ON	ON	OFF	OFF
	1.6	ON	OFF	ON	ON

*0.125 flow rate setting only available if ordered that way from the factory
Flush Valves are preset to 1.0 GPF for urinal and 1.6 GPF for closet
For alternate flow rates not listed, please contact Hydrotek direct

Sensor Arming Time

Sensing Time Required to Flush

Urinal	Standard	OFF	OFF	OFF	ON	3 seconds
	Optional	ON	OFF	OFF	OFF	1.5 seconds

Closet	Standard	ON	OFF	OFF	OFF	4 seconds
	Optional	OFF	OFF	OFF	OFF	8 seconds

NOTE: PUSH THE RESET BUTTON ON THE CONTROL MODULE AFTER ANY ADJUSTMENTS TO THE DIP SWITCHES.

Sensor Distance Adjustment

Clockwise	Increase sensing distance
Counter-Clockwise	Decrease sensing distance