



ISO 9001 Certified

HB8-16DF

1.6 / 1.1 GPF Dual Flush

Battery Powered Flush Valve (Closet)

Description

Battery powered, sensor operated, water conserving, closet flush valve for floor mounted or wall hung top spud bowls.

Flush Cycle

- Activate sensor for 60 seconds or less = 1.1 GPF
- Activate sensor for 61+ seconds = 1.6 GPF
 - * Flush valves may not function with all bowls. Be sure to verify flow requirements with bowl manufacturer.
 - * Flow rate is field adjustable

Specifications

Exposed, Piston Operated, Chrome Plated, Closet Flush Valve with the following features:

- Standard Brass/Chrome Plated All Metal Construction
- Superior, Slow-Closing, Piston Flushing Mechanism
- Standard Manual –Mechanical Override Button
- Field Adjustable to Left or Right Rough-In
- Operating Pressures: 10-125 PSI
- Standard Self-Cleaning Filtering System
- Superior VSI Silicone Elastomer Piston Seals are Unaffected by Chlorine, Chloramines, and Ammonia
- ADA Compliant—Infrared Sensor Operated for “No Hands” operation
- Self-Diagnostic Electronic System with Manual Reset
- Reliable, Latching Solenoid Valve
- Preset / Adjustable Sensor Distance
- Adjustable Tailpiece
- 1” I.P.S. Angle Stop Valve with Vandal Resistant Cap
- High Back Pressure Vacuum Breaker / Flush Tube Connection
- Spud Coupling and Flange for 1 1/2” Top Spud
- Sweat Solder Adapter with Cover Tube and Wall Flange
- High Copper, Low Zinc Brass Casting for Dezincification Resistance
- 36-hour Sentinel Flush
- (4) AA Alkaline Batteries—Furnished

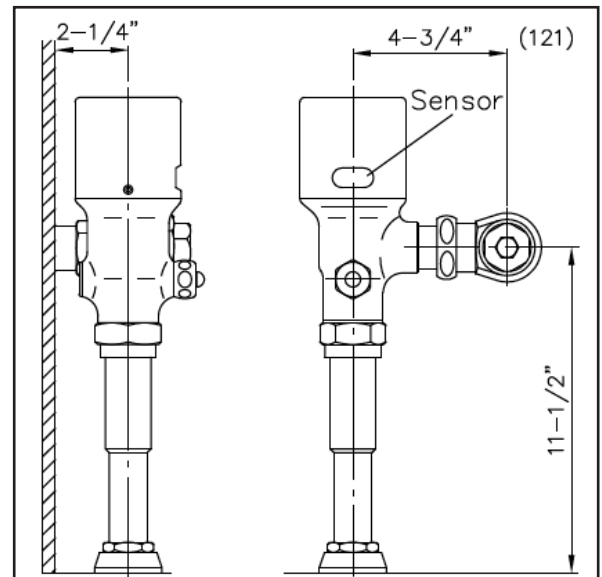

Electrical Specifications

- Battery: (4) AA Alkaline Batteries
- Solenoid Valve and Sensor, 6V DC
- Battery Service Life: 400,000 flushes, up to 4 years

HYDROTEK INTERNATIONAL, INC.
5055 Forsyth Commerce Rd., Ste 124
Orlando, FL 32807
800.922.9883 (Phone)
866.670.5580 (Fax)
www.hydrotekintl.com

