



4100-LR Series

U.S. Patent 8474481B2

Sensor Faucets and Flush Valves

AC or Battery Powered Sensor Operated Faucet

The 4100-LR Series faucet is a single-hole deck mounted, piston operated sensory faucet that provides a vandal resistant, Lead Free, no touch solution with integral hot/cold ceramic mixing and manual on/off adjustment that promotes better hygiene and energy savings.

Designed to be easy to install and maintain, all major faucet components are encased above deck, making for easier access. The sensor included in this faucet is self adapting, meaning manual adjustments are not necessary.

- **ADA Compliant.** Meets all barrier free codes
- Conserves water and energy
- Easily installed in new or retrofit applications
- Competitively priced for today's commercial market
- Promotes cleanliness & hygiene
- Proven Hydrotek craftsmanship and reliability
- Temperature adjusting handle with manual on/off
- Lead Free

Models:

- ✓ H-4100-LR: Lead Free, AC Powered
- ✓ HB-4100-LR: Lead Free, Battery Powered
- ✓ HE-4100-LR: Lead Free, Battery Powered with Enduratek **NEW!**

Features:

- Vandal-resistant faucet body with chrome plated, solid brass construction.
- Faucet design allows quick "above the deck" access to all major faucet component parts.
- 30 second time-out feature prevents accidental sink overflow.
- Integrated ceramic faucet mixing valve (with built-in checks) allows for precise hot/cold mixing.
- "Above the deck" external or internal temperature adjustment variation.
- Standard 0.5 GPM flow control for water conservation and annual savings.
- "Self-adapting" sensor distance adjustment eliminates need for manual sensor adjustments.
- Low battery indicator light (battery powered models)
- Single-hole deck mounting with optional 4" and 8" cover plate for vandal resistant, three point anchoring.
- Manual override provides continuous water flow for special applications or in case of power failure.
- Manually controlled temperature adjustment.
- Patented electronics and slow closing solenoid valves provide reliable and smooth operation without water hammer.
- Includes in-line filter adapter for easier cleaning.
- Superior VSI silicone elastomer piston seals are unaffected by chlorine, chloramines, or ammonia.



Hydrotek Automatic Faucets

4100-LR Series

Deck Mounted / Mixing

Meets ANSI/ASME A112.18.1 M-1989

Operation:

1. A continuous, invisible beam is emitted from the sensor.
2. The faucet is activated by placing hands under the spout within the effective range of the beam. Water starts to flow immediately for as long as the user's hands remain in the sensor range.
3. When hands are removed, the water flow stops. The sensor will automatically reset and be ready for the next user.
4. Water temperature adjustment can be easily accessed with external adjuster.

Specifications:

Faucet Construction: Solid brass, chrome plated

Control Circuit:

Auto. Time-out: 30 seconds

Sensor Range: Self adapting

Shut-off Delay: 1 second

Line Purge (request only) . . . 2 min run every 12 hr or 24 hr

Scrub Mode (request only) . . 60, 120, 180 seconds

Solenoid Valve: 6V DC, normally closed

Wattage: 0.2W (idle), 3W (in use)

Operating Pressure: 5 psi to 125 psi

Flow Control: 1.5 GPM, Rosette, Vandal Resistant

AC Mode

Power Adapter (UL/CSA)

Standard Plug-in: Input AC 120V 60 Hz or 220V
Output DC 7.5V, 0.8A/Class 2

Power Cable: Armored, vandal resistant

Optional Multi-Unit Adapter: . . Serves up to 6 faucets
(UL/CSA) Input AC 120V, Output DC 7.5V, 3A

Battery/Enduratek Mode

Battery Powered Models: (4) AA Alkaline Batteries

Battery Service Life: 400,000 on/off cycles, up to 4 years

Enduratek Service Life: 1.5 million on/off cycles, up to 10 years

Warranty: 3 years

Package Includes:

- (1) Faucet with sensor/solenoid
- (1) 6" Gooseneck spout
- (1) Armored S.S. supply tube with filter
- (1) Mounting hardware
- (1) 2.2 GPM Laminar Flow Control
- (1) 7.5V DC plug-in power adapter (*H-4100-LR only*)
- (4) AA Alkaline batteries (*HE-4100-LR only*)

Dimensions:

Base Width (Outside Measurement) 4-7/16"

Base Depth 2-1/16"

Faucet Height (Aerator to Base) 6-7/8"

Faucet Height Overall 10-1/2"

Depth (Aerator to Base) 5-5/8"

Mounting Bolt Length 2"

Mounting Bolt Pattern Single-hole mount

Optional Variations and Accessories

- 0.35, 1.5, 2.0, 2.2 GPM Laminar Flow Control
- HC-010E Multi-Unit Voltage Adapter (AC Powered Only)
- Different spout styles and sizes available upon request
- 4" or 8" Centerset Cover Plate
- HBL-04 Thermostatic Mixing Valve with Check

4100-LR

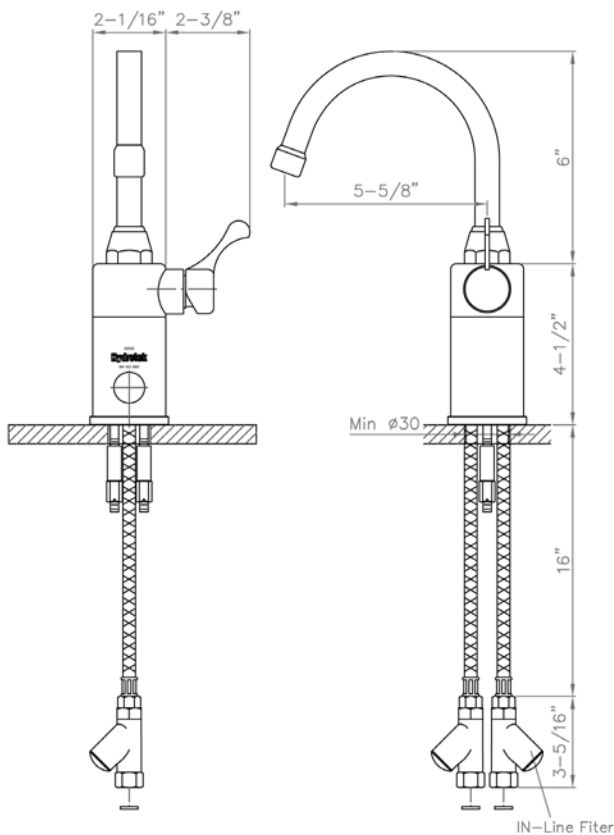

HYDROTEK INTERNATIONAL, INC.
5055 Forsyth Commerce Rd., Ste 124
Orlando, FL 32807
800.922.9883 (Phone)
866.670.5580 (Fax)
www.hydrotekintl.com

