



## 8000 Series

U.S. Patent 6192530B1, 5699994

### Sensor Faucets and Flush Valves

### AC, Battery, or Solar Powered Sensor Operated Flush Valves

The Hydrotek 8000 Series Automatic Flush Valves are the most advanced, electronic flushing system in the industry today. By incorporating our field-tested electronic circuitry and slow-closing solenoid valves, Hydrotek has developed an innovative non-diaphragm, piston flushing mechanism that will provide years of dependable and trouble-free service. The Hydrotek AUTOFLUSH system is completely automatic: there is no need to contact any surface, no handle to push, and it flushes only when it is used. It provides the ultimate sanitary protection, the convenience of cleaner restroom facilities, and the most efficient system in water conservation.

- **ADA Compliant.** Meets all barrier free codes
- Conserves water and energy
- Easily installed in new or retrofit applications
- Competitively priced for today's commercial market
- Promotes cleanliness & hygiene
- Proven Hydrotek craftsmanship and reliability

#### H-8000C Series (AC)

Complete Units

#### HB-8000C Series (Battery)

Complete Units

#### HB8RFKC Series (Battery)

Complete Units

#### HB-8000SLE Series (Solar)

Complete Units



## Features:

- **ACCU-SENSE** adjustable sensor eyes
- Standard manual mechanical override button for both urinals & water closets
- Standard brass/chrome-plated, all metal construction with other finishes available
- AC/DC powered - field switchable
- Preset/adjustable flow rate and sensor distance
- Self-diagnostic electronics
- Standard vandal resistant stop valve (complete units only)
- Superior piston flushing mechanism
- Field adjustable for left and right rough-in
- Battery replacement without water shut-off
- Operating pressures: 10-125 PSI
- Standard self-cleaning filtering system
- Switchable from/to urinal or closet
- 36 hour sentinel flush
- Superior VSI silicone elastomer seals, unaffected by chlorine, chloramines or ammonia
- AC with DC backup models automatically switch to batteries during a power outage
- Uses inexpensive AA batteries
- Battery service life: 400,000 on/off cycles (650,000 for the HB-8000SLE Series)
- Low battery indicator light (battery powered only)
- No outside power source required (battery powered only)
- Can be installed by one tradesperson (battery powered only)

# Hydrotek Autoflush Valves

## 8000 Series

Meets A.S.S.E. Standard 1037-89

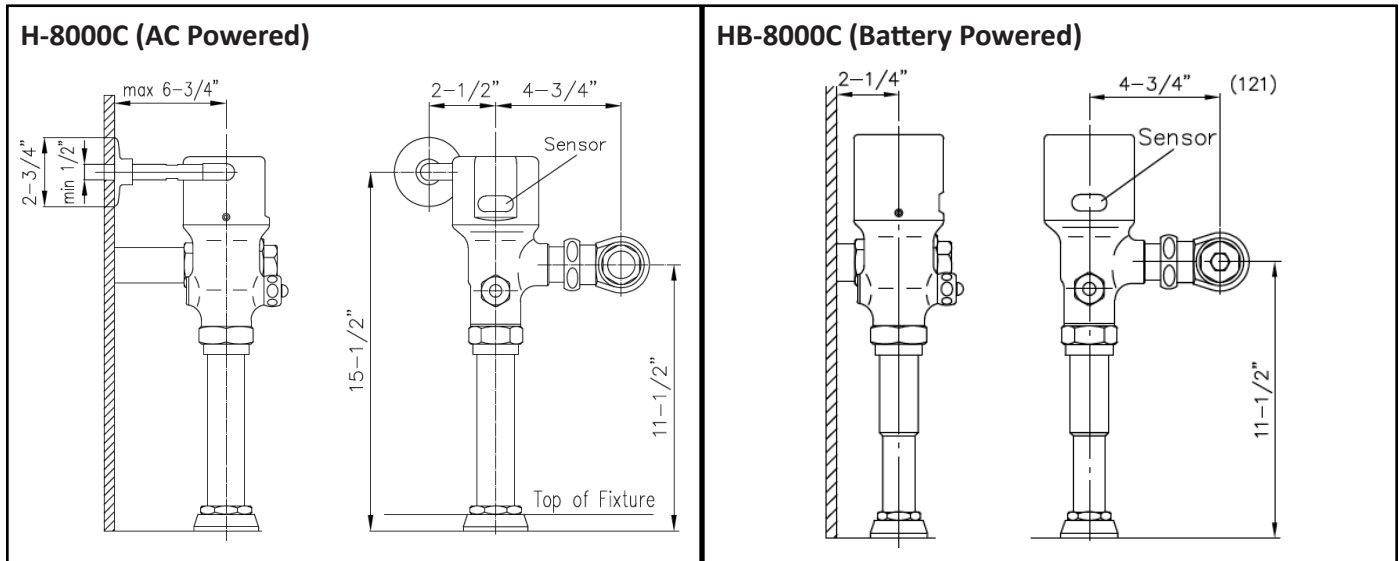

The 8000 Series Flush Valves are available in:

### H-8000C Series (AC Powered):

- ✓ H-8000C-A (Closet)
- ✓ H-8000C-B1 (Urinal)
- ✓ H-8000C-B2 (Urinal)

*\*Water conservation, concealed and AC with DC backup models available\**

### HB-8000C Series (Battery Powered):

- ✓ HB-8000C-A (Closet)
- ✓ HB-8000C-B1 (Urinal)
- ✓ HB-8000C-B2 (Urinal)

*\*Water conservation and concealed models available\**

### HB-8000SLE Series (Solar Powered):

- ✓ HB-8000SLE-A (Closet)
- ✓ HB-8000SLE-B1 (Urinal)
- ✓ HB-8000SLE-B2 (Urinal)

*\*Water conservation and retrofit models available\**

### HB8RFKC Series Retrofit Models (Battery Powered):

Sloan & Zurn Retrofit

- ✓ HB8RFKC-C (Closet)
- ✓ HB8RFKC-U (Urinal)

Delany Retrofit

- ✓ HB8RFKC-CD (Closet)
- ✓ HB8RFKC-UD (Urinal)

*\*Water conservation models available\**

### HYDROTEK INTERNATIONAL, INC.

5055 Forsyth Commerce Rd., Ste 124  
Orlando, FL 32807  
800.922.9883 (Phone)  
866.670.5580 (Fax)  
www.hydrotekintl.com



### PLUMBING SPECIFICATIONS:

Model	Fixture	Supply Line	Top Spud	Flow Rate
H/HB-8000C-A	Closet	1"	1-1/2"	1.6 GPF
H/HB-8-128	Closet	1"	1-1/2"	1.28 GPF
H/HB-8000C-B1	Urinal	3/4"	3/4"	1.0 GPF
H/HB-8000C-B2	Urinal	1"	1-1/4"	1.0 GPF
HB8RFKC-C/U	Cl. & Ur.	N/A	N/A	0.5-3.5 GPF

### ELECTRICAL REQUIREMENTS:

- AC Powered Units:
  - Solenoid valve and sensor: 6V DC
  - Transformer: Input 120V AC, 60 Hz  
Output 12V DC
- Battery Powered Units
  - Solenoid valve and sensor: 6V DC
  - Battery: (4) AA Alkaline Batteries
  - Battery Service Life:
    - ☑ 400,000 flushes, up to 6 years (Battery)
    - ☑ 650,000 flushes, up to 10 years (Solar)

### BASIC PACKAGE INCLUDES:

	H-8000C (-A, -B1, -B2)	HB-8000C (-A, -B1, -B 2)	HB8RFKC (-C, -U)	HB-8000SLE (-A, -B1, -B2)
(1) Flush Valve	✓	✓	✓	✓
(1) Stop Valve	✓	✓		✓
(1) Sweat Kit	✓	✓		✓
(1) Flush Tube	✓	✓		✓
(1) Spud Coupling	✓	✓		✓
(1) Vacuum Breaker	✓	✓		✓
(1) AC Adapter	✓			
(1) AC Input Tube	✓			
(4) AA Batteries		✓	✓	✓

### OPTIONAL ACCESSORIES:

- HC-010 Multi-Unit Power Adapter (AC only) - 8 units
- HC-0104 Multi-Unit Power Adapter (AC only) - 4 units