

HYDROTEK INTERNATIONAL, INC.

5055 Forsyth Commerce Rd., Ste. 124, Orlando, FL 32807

Phone (800)922-9883 / Fax (866)670-5580

www.hydrotekintl.com

OPERATION & MAINTENANCE MANUAL

HYDROTEK MODEL #H-1000C FAUCET

TECHNICAL SUPPORT TEAM:

Michael Hu & Armin Kharazi

Phone (800) 922-9883 ext. 105

Email: mike@hydrotekintl.com or armin@hydrotekintl.com



Solid Brass AC or Battery Powered

Automatic Faucet

1000C Series

ISO 9002 Certified



High Technology For No Touch Operation

- ADA Compliant. Meets all barrier free codes
- Conserves water and energy
- Easily installed in new or retrofit applications
- Competitively priced for today's commercial market
- Promotes cleanliness & hygiene
- Proven Hydrotek craftsmanship and reliability

1000C Series

U.S. Patent: 6192530B1

Features:

- **ACCU-SENSE** adjustable sensor eyes.
- All solid metal construction.
- Wall mountable, waterproof control box with armored, vandal resistant control and power cables.
- Preset/adjustable sensor range 6" – 30" for various installation requirements.
- Standard automatic time-out feature. Preset at 30 but adjustable to 0, 15 or 60 seconds. Prevents accidental sink overflow.
- Shut-off delay is adjustable from 1 second (preset) to 8 seconds.
- Solid brass body with cast 4" center-set and 3 point anchoring system. Twist-free and tamper resistant. Adapts to 8" center-set.
- Includes in-line filter with clean-out trap to reduce maintenance costs.
- All parts are field-replaceable to ensure quick and easy repair.
- Same faucet, field switchable to/from AC Powered or Battery Powered.
- Slow closing, piston-operated solenoid valve provides reliable and smooth operation without water hammer.
- Superior VSI silicone elastomer piston seals are unaffected by chlorine, chloramines or ammonia.
- Standard 0.5 GPM Flow Control for water conservation and annual savings.
- Control module automatically performs a unique self-check of all electrical components.

Hydrotek Non-Mixing Automatic Faucet

Model H-1000C (AC) or HB-1000C (Battery)

Meets ANSI/ASME A112.18.1 M-1989

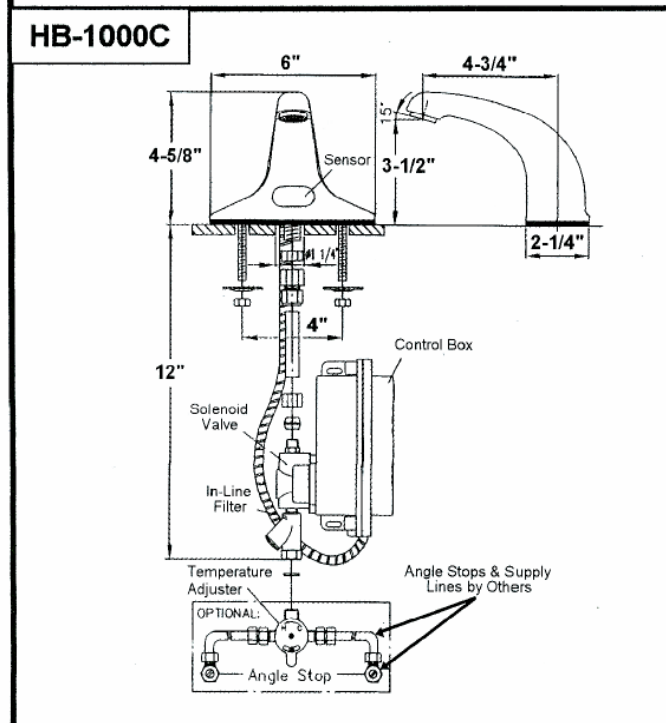
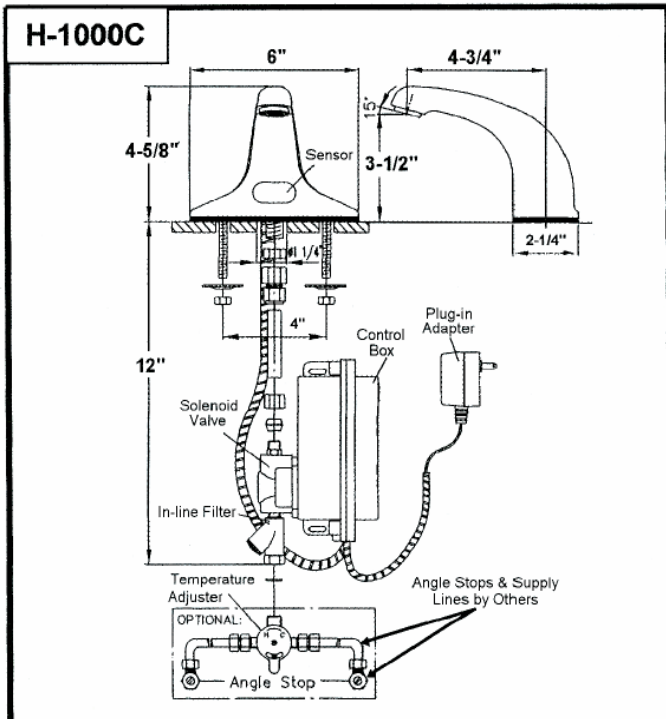

Operation:

1. A continuous, invisible beam is emitted from the sensor.
2. The faucet is activated by placing hands under the spout within the effective range of the beam. Water starts to flow immediately for as long as the user's hands remain in the sensor range.
3. When hands are removed, the water flow stops. The sensor will automatically reset and be ready for the next user.
4. In battery powered mode, flashing red light will indicate low battery condition.

Specifications:

Faucet Construction	- Solid Brass, Chrome Plated
Control Circuit	- Solid state, AC or Battery, Switchable
Auto. Time-out:	- Preset and Adjustable for 0, 15, 30, or 60 seconds
Sensor Range:	- Preset and Adjustable
Shut-Off Delay:	- Preset and Adjustable from 1 – 8 seconds
Control Cable:	- Armored, Vandal Resistant
Solenoid Valve:	- 6V DC, Normally closed - Wattage: 0.4W (idle), 5W (in use) - Operating Pressure: 5 psi to 125 psi
Flow Control:	- 0.5 GPM, Vandal Resistant

AC Mode

Power Adapter	
Standard plug-in:	- Input AC 120V 60 Hz or 220 V (UL/CSA)
Power Cable:	- Armored, Vandal Resistant
Optional Multi-Unit Adapter:	- Serves up to 8 Faucets (UL/CSA)

Battery Mode

Battery Powered Models:	- (4) AA Alkaline Batteries
Battery Service Life:	- 400,000 on/off cycles, up to 4 years

Standard Package Includes:

<i>H-1000C (AC)</i>		<i>HB-1000C (Bat)</i>
X	(1) Faucet with Electronic Sensor	X
X	(1) Control Box w/6V DC Solenoid	X
X	(1) 12V DC Plug-in Power Adapter	
X	(1) In-Line Filter with Clean-Out Trap	X
X	(1) Copper Supply Tube, 3/8"	X
X	(1) Mounting Hardware	X
X	(1) 0.5 GPM Vandal Resistant Flow Control	X
	(4) AA Alkaline Batteries	X
	(1) Battery Holder	X

Dimensions:

Base Width (Outside Measurement)	6"
Base Depth	2-1/4"
Faucet Height (Aerator to Base)	3-1/2"
Faucet Height Overall	4-5/8"
Depth (Center of Aerator to Center of Faucet Base)	4-3/4"
Mounting Bolt Length	2-1/2"
Mounting Bolt Pattern	4" Centers

Optional Variations and Accessories:

- 1.6GPM VR Soft-Flow Aerator. 1.5, 2.0 & 2.5 GPM Laminar Flow
- 8" Centerset Cover Plate
- HC-010 Multi-Unit Voltage Adapter (AC Powered Only)
- HC-001 Mixing/Check Valve (Mechanical)
- HBL-04 Thermostatic Mixing Valve with Checks

HYDROTEK INTERNATIONAL, INC.

5055 Forsyth Commerce Rd., Ste. 124

Orlando, FL 32807

1.800.922.9883 (Phone)

1.866.670.5580 (Fax)

www.hydrotekintl.com



INSTALLATION INSTRUCTIONS

Hydrotek Non-Mixing Automatic Faucet (AC Powered)

Model H-1000C

1. Prior to installing this faucet, thoroughly flush all water lines and replace stop washers, if necessary.
2. To ensure proper operation, " DRY TEST " the faucet by plugging (14) Sensor eye cable connector into the matching connector on the PC board inside the (15) Control box. Plug (17) Power adapter output connector into matching connector on PC board located inside the (15) Control box. Plug (17) Power adapter into 120 V AC outlet. Place your hand in front of faucet sensor eye. If there is a clicking sound, the faucet is activating properly. If not, call the factory.
3. After successful "DRY TEST," unplug connectors from both the Sensor eye cable and Power adapter to the PC board.
4. Attach (6) Compression adapter, (7) Supply tube, and (2) Mounting bolts to (1) Faucet body inlet.
5. Install (3) Gasket on faucet and set unit on sink. Apply plumbers putty to bottom of gasket. Secure the faucet unit to the sink using (4) Slotted washers and (5) Mounting nuts.
6. Connect electrical Sensor eye cable and Power adapter as described in STEP #2, making sure that the Sensor eye and Power adapter cables are seated into the Control box housing properly. Reinstall Control box cover and tighten screws to insure that the box is water-resistant. Coil excess Power Adapter wire and secure in a safe, dry area.
7. Attach (11) Solenoid valve outlet to (7) Supply tube using (8) Compression nut, (9) Compression ferrule, and (10) Compression fitting. Insert (13) Nylon washer into swivel nut located on (12) In-line filter inlet (**for pre-tempered or cold water only**). Using a union fitting (not supplied), connect supply line (not supplied) from supply stop to (12) In-line filter inlet swivel nut (**for tempered water**).
 >>Attach optional Hydrotek HC-001 Mixing/Check Valve or HC-003 Mixing "T" w/checks to In-line filter inlet. Connect supply lines (not supplied) from hot and cold supply stops to Mixing valve or Mixing "T" inlets.
Use Teflon Tape, not Pipe Dope for all connections.
8. Turn on water and check for leaks. Plug (17) Power adapter into 120V AC outlet. Place hand in front of Sensor eye to activate water flow. Remove hands and water should stop. If not, refer to troubleshooting guide.
9. Periodically clean the filter element located inside the In-line filter.
10. For minor adjustments, refer to the instructions located inside the Control box cover.

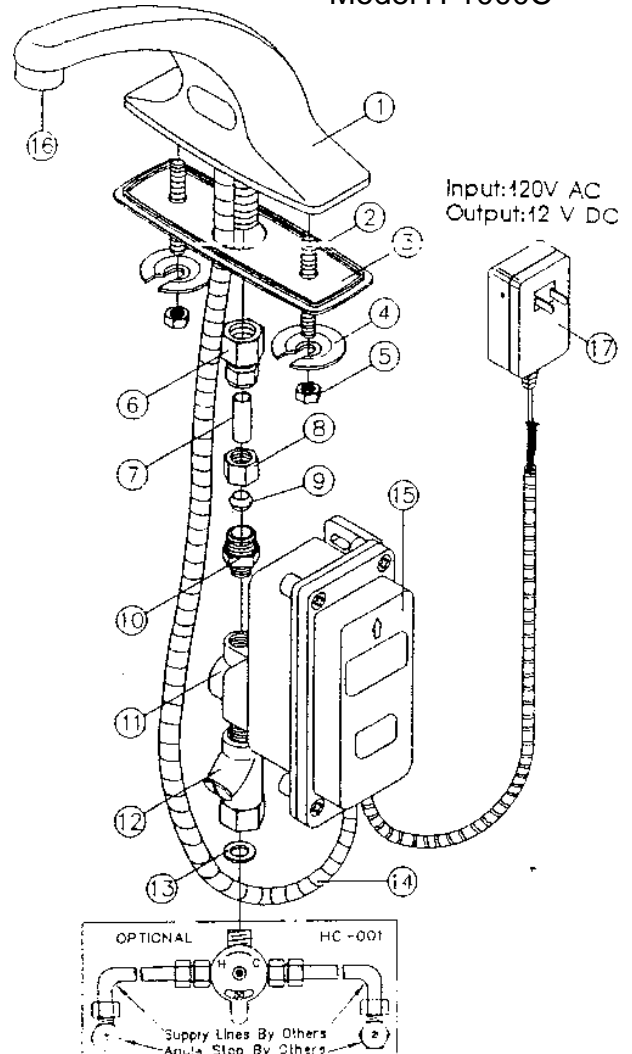

Part Number Descriptions	
1. Faucet body	10. Compression fitting
2. Mounting bolt	11. Solenoid valve
3. Gasket	12. In-line filter
4. Slotted washer	13. Nylon washer
5. Mounting nut	14. Sensor eye cable
6. Compression adapt.	15. Control box
7. Supply tube	16. Aerator
8. Compression nut	17. Power adapter
9. Compression ferrule	

HYDROTEK INTERNATIONAL, INC.
 5055 Forsyth Commerce Rd. , Ste. 124
 Orlando, FL 32807
 1.800.922.9883 (Phone)
 1.866.670.5580 (Fax)
 www.hydrotekintl.com

NO	DESCRIPTION	PART NO.	NO	DESCRIPTION	PART NO.
1	Body	H1-01D-01A	27	Valve Seat	HB-011-03
2	O-Ring(H023)	HC-014-11	28	O-Ring(H031)	HC-014-61
3	Nut	H1-01B-03D	29	Rubber Plug	HB-02-06
4	Screw*4	HC-013-47	30	Control Disc+Rubber	HC-005-03E
5	Sensor Cover	PC-004-31A	31	Control Disc Spring	HC-003-03
6	O-Ring(H118)	HC-014-16	32	O-Ring(H022)	HC-014-30
7	O-Ring(H021)	HC-014-33	33	O-Ring(H023)	HC-014-11
8	Sensor Eye & Cable	PC-006-26A	34	Control Valve	HB-05-04
9	Screw*2	HC-013-27	35	O-Ring(H013)	HC-014-03
10	Mounting Bolt*2	H1-03-0101	36	Piston Tip	HB-04-09A
11	Gasket	H1-01-02D	37	Piston	HB-04-08A
12	Mounting Washer*2	H1-03-0103	38	Piston Spring	HB-04-07A
13	Mounting Nut*2	H1-03B-0102	39	Piston Shaft	HB-04-06A
14	O-Ring(H012)	HC-014-18	40	Coil	HB-04-05A
15	Mounting Bolt	B2-01B-02	41	Rubber Gasket	HB-04B-E
16	Compression Reducer	HC-009-12	42	Washer *4	HB-01-20
17	Supply Tube	H6-01-07	43	Screw *4	HC-013-35
18	Compression Nut	HC-001B-08A	44	Control Box	HB-012-0101
19	Ferrule	HC-001-07A	45	Screw *2	HC-013-52
20	Compression Adaptor	H1-03B-0104A	46	P.C.B	PC-009-32
21	Screw*4	HC-013-57	47	Seal Rubber	HB-012-0102
22	Filter Body	HC-023D-A	48	O-Ring(006)*4	HC-014-62
23	Nylon Washer	HC-002-04A	49	Box Cover	HB-012-0201
24	Filter Screen	HC-009-03	50	Screw *4	HC-013-52
25	O-Ring(H016)	HC-014-36	51	Ac Adaptor	HC-012-07D
26	Filter Cap	HC-023D-02			

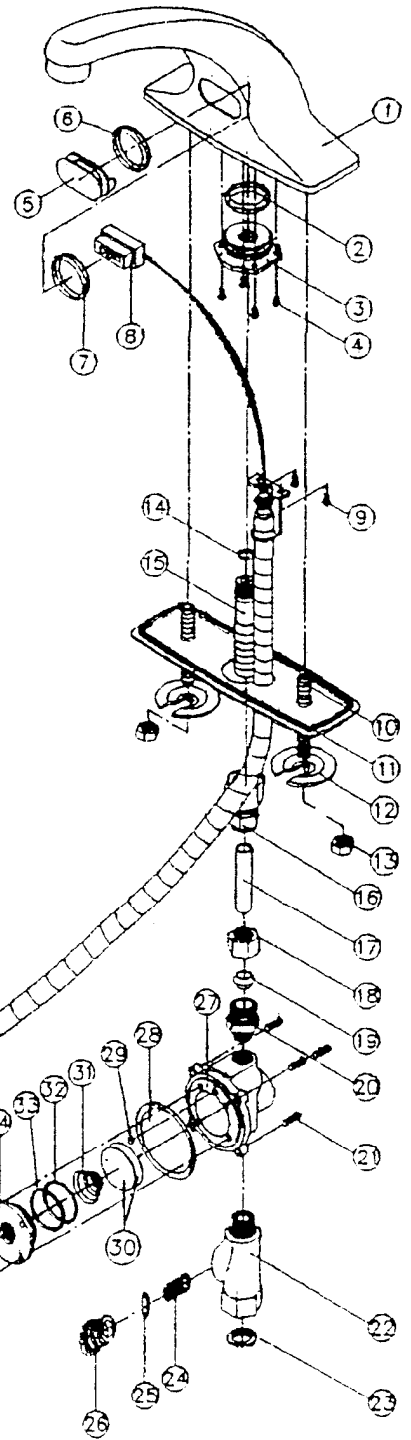

HYDROTEK Model H-1000C

HYDROTEK AUTOMATIC FAUCET TROUBLESHOOTING GUIDE

(AC Powered)

Normal Operation: When power is connected or RESET button is pushed, the lights on the Printed Circuit Board (PCB) will blink in the following sequence: red – red (with solenoid clicking) – green – red – red. Green light will remain lit. When the user's hands are placed under the spout, the red indicator light on the faucet and PC board will illuminate and water will begin to flow. Water flow will stop when hands are removed. Always push the RESET button BEFORE attempting to diagnose any problem and AFTER taking corrective action.

<u>PROBLEM</u>	<u>POSSIBLE CAUSE</u>	<u>TO DIAGNOSE</u>	<u>REMEDY</u>
Faucet will not turn on:	Water not turned on.	Check water supply.	Turn water on.
	Power supply failure.	Check power adapter voltage, polarity, wires, and connections.	Replace power adapter and reconnect. Push RESET button.
	Sensor distance is too short.	Use hand/palm to find focal point of sensor beam.	To adjust sensor distance out, turn adjustment clockwise. Push RESET button.
	Electronic PCB is defective.	With power adapter plugged in, push RESET button. No light, no action.	Replace PCB.
	Sensor eyes are defective.	With power adapter plugged in, place hands in front of sensor eyes. Indicator light on faucet does not blink.	Replace sensor eyes and cable.
	Solenoid valve is clogged.	Solenoid is clicking but no water is coming out.	Clean solenoid and blow free all by-pass holes. Replace control disc. Push RESET button.
	In-line filter is clogged.	Open clean-out trap and check filter screen.	Clean or replace filter screen.
	Solenoid coil is defective.	With power adapter plugged in, push the RESET button. Light blinks but no solenoid clicking.	Replace solenoid coil. Push RESET button.

Faucet will not shut off: Solenoid valve is normally closed. Turn off water and activate faucet. If there is a clicking sound, the solenoid valve is dirty. If there is no clicking sound, then replace solenoid valve. Other factors could be problematic (Sensor distance adjustment could be too long or electronic PCB could be defective). If the faucet is dripping, the solenoid valve needs a rebuild kit. Follow the same procedures as above for remedies.

IMPORTANT: Periodic maintenance is required for smooth and trouble-free operation of this faucet.

For more detailed remedy procedures, please call Hydrotek Tech Support at (800)922-9883 ext. 105

SOLENOID VALVE CLEANING FOR HYDROTEK 1000C, 2603C, 6000C, 6700C FAUCETS (AC AND BATTERY POWERED)

1. Turn off water supply at stop valve.
2. Remove control box (if possible) to gain access to the solenoid valve.
3. Remove four Screws (#21) and separate the valve from the box.
4. Remove four Coil Screws (#43) and separate Coil (#41) from Valve Seat (#27).
5. When separating Plastic Control Valve (#34) be careful to retain the small Orange Rubber Plug (#29). Re-install this on Brass Valve Seat (#27).
6. Clean or replace Control Disc (#30), Disc Spring (#31), Piston & Tip (#36 and 37), Piston Spring (#38), and check Sleeve (#39) for corrosion.
7. Re-install all parts in same order as the diagram below.
8. Re-install solenoid on the control box and re-mount box in water line.
9. Check and clean Filter Screen (#24) in Filter Body (#22).
10. Reset P.C. Board and make sure solenoid clicks open and thumps closed.
11. Turn on water and check for leaks and proper operation.

(For further questions, please call Hydrotek Tech Support at 1-800-922-9883 ext. 105)

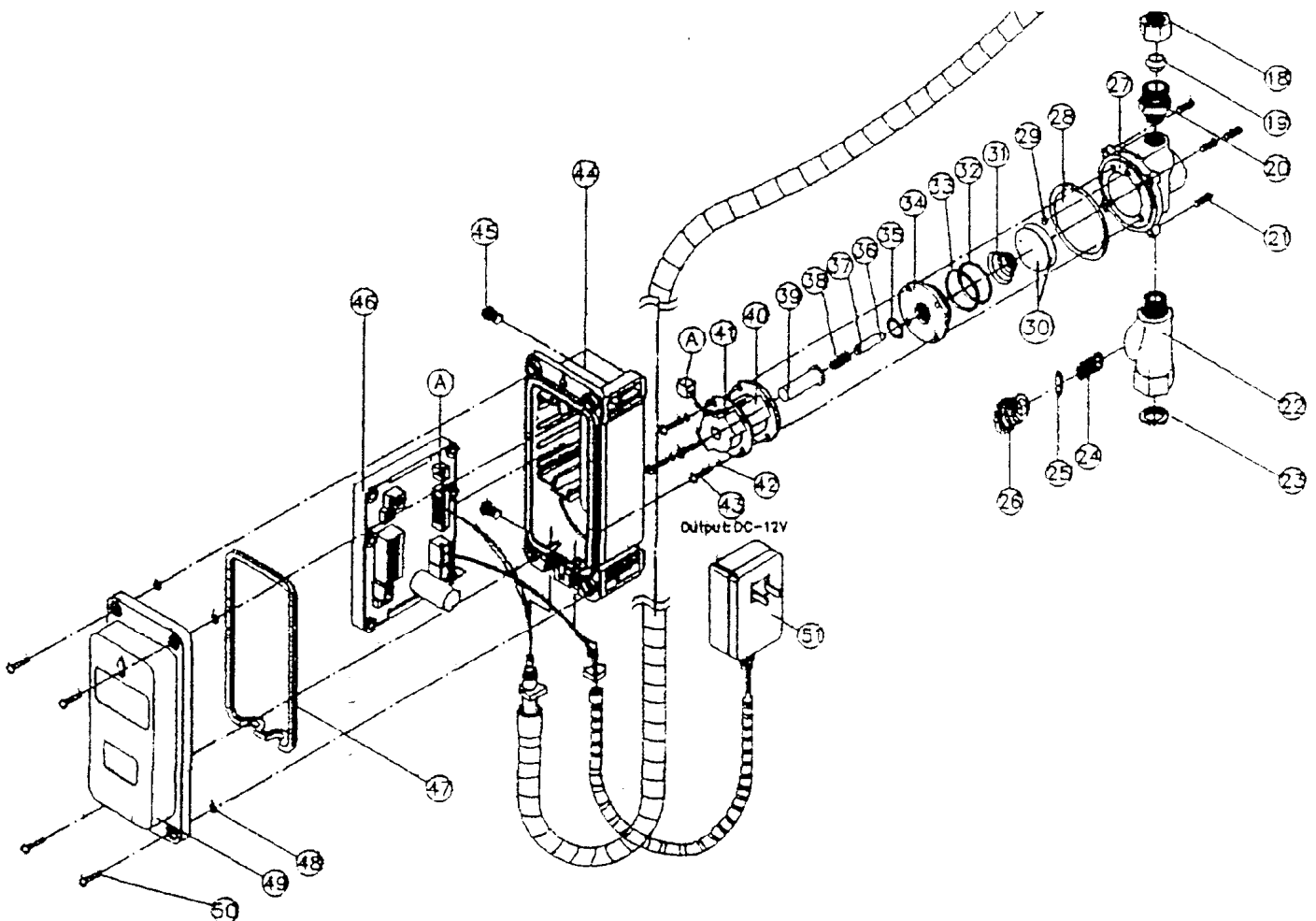

SENSOR EYE AND CABLE REPLACEMENT FOR 1000C SERIES FAUCETS (AC OR BATTERY POWERED)

1. Remove faucet body from sink deck to gain access to the bracket underneath the body.
2. Remove the two Screws (#9) holding the eye bracket on the body.
3. CAREFULLY PRY Sensor Eye (#8) out of Sensor Cover (#5).
4. Firmly push the NEW eye into Sensor Cover. You should hear a snap when the eyes are in place.
5. Plug the new eye and cable into the connector on the P.C. Board in the Control Box (#44).
6. Test for proper operation and remount the body on the sink.

*For any questions, please call Hydrotek Tech Support
at (800) 922-9883 ext. 105.*

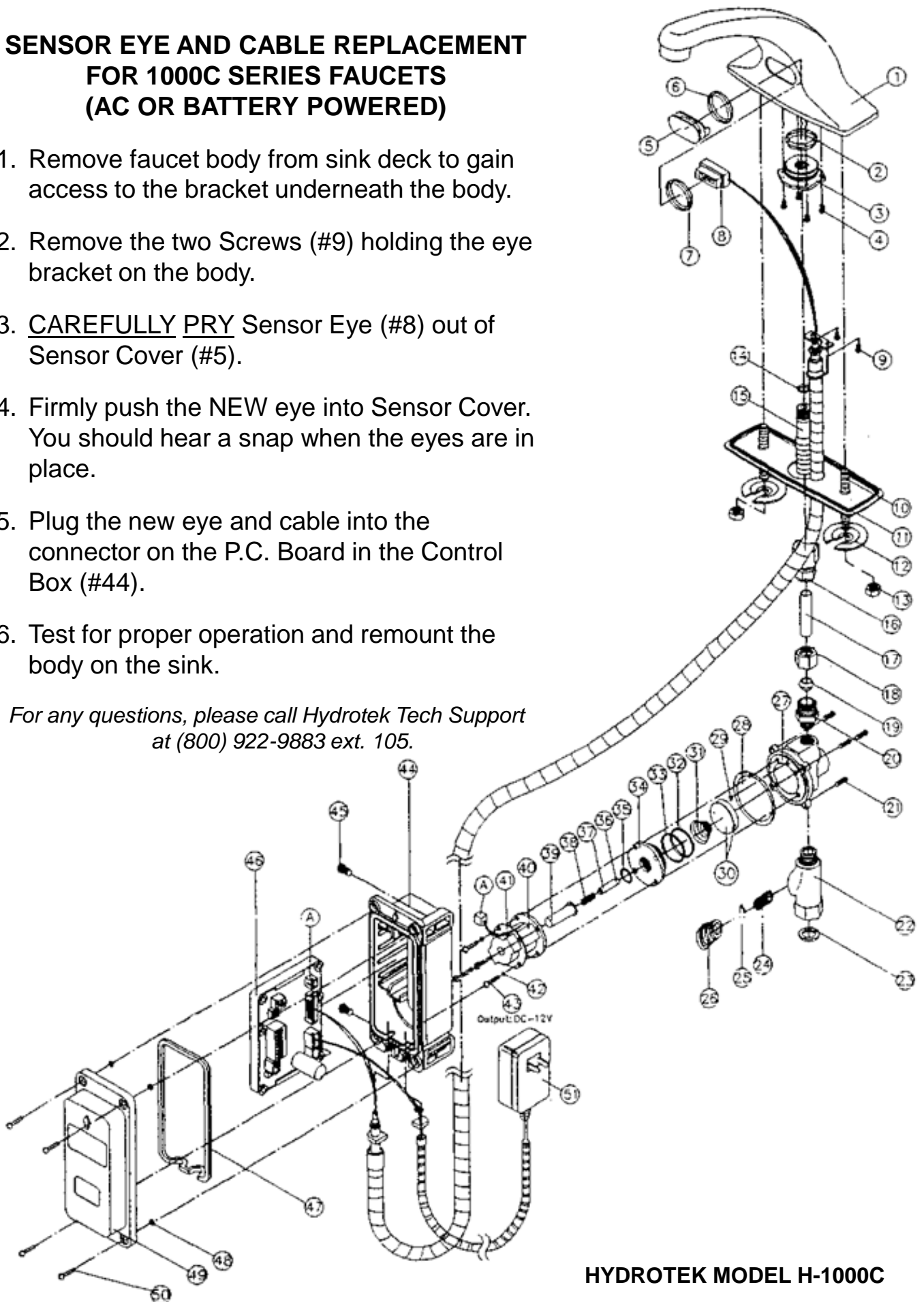

HYDROTEK MODEL H-1000C

HYDROTEK AUTOMATIC FAUCET: DIP SWITCHES

NOTE: ALWAYS PUSH THE RESET BUTTON AFTER ANY ADJUSTMENTS

A. Shut Off Time Delay (After hands are removed):

Sw 1	Sw 2	Sw 3	Time Delay
ON	ON	ON	1-Sec
ON	ON	OFF	2-Sec
ON	OFF	ON	3-Sec
ON	OFF	OFF	4-Sec
OFF	ON	ON	5-Sec
OFF	ON	OFF	6-Sec
OFF	OFF	ON	7-Sec
OFF	OFF	OFF	8-Sec

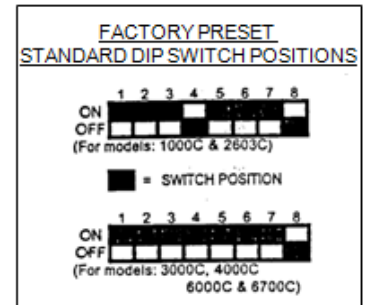

B. Automatic Time Off (Maximum run time after activation):

Sw 4	Sw 5	Time Off
ON	ON	0 Sec
ON	OFF	15 Sec
OFF	ON	30 Sec
OFF	OFF	60 Sec

C. Sensor Distance: To increase distance, turn SDA screw clockwise.
To decrease distance, turn screw counter-clockwise.

Sw 6	Mode	Distance
ON	Std	4" – 12"
OFF	Enhanced	10" – 24"

D. Faucet Switch:

Sw 7	Sw 8	Product
ON	OFF	Auto Faucet

Control Module Diagram for C-Series Faucets

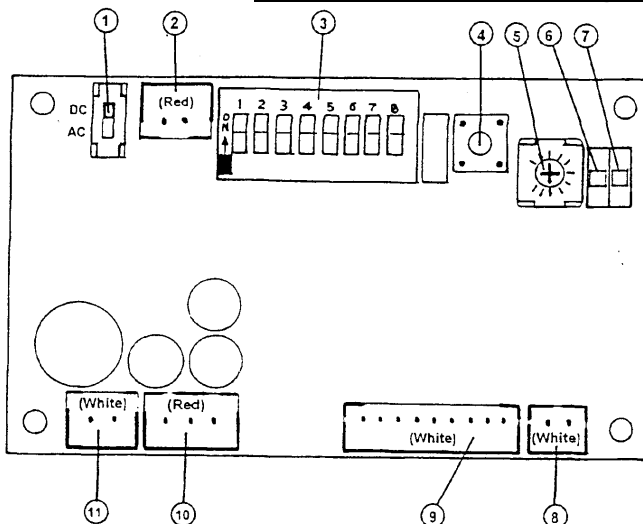

1. AC/DC Switch
2. Battery Holder Pin Connector (Red)
3. Dip Switches
4. Reset Button
5. Sensor Distance Adjustment (SDA)
6. Indicator LED (Green)
7. Indicator LED (Red)
8. Solenoid Pin Connector (White)
9. Sensor Eye Control Cable (White)
10. AC Power Adapter Pin Connector (Red)
11. Battery Holder Pin Connector (White)

Hydrotek International, Inc.
 Phone: 800-922-9883 / Fax: 866-670-5580

Suggested Backup Parts for 1000C Series Faucets
 AC or Battery Powered Lavatory Faucets

Part Number From Drawing	Hydrotek Item Code	Description
51	HCC-008B	12V AC Adapter (AC Model)
22-26	HC-009B	Filter without Check
8	HCC-030	Sensor Eye & Cable
46 46	HCC-011A HCC-011B	Module – PCB for AC Model Module – PCB for Battery Model
10,12,13	HC-015	Mounting Kit
24	HC-020	Filter Screen
30,31,35,36,37,38	HCB-017A	Valve Repair Kit
40	HCC-019	Solenoid Coil
30	HCB-005A	Control Disc Only
23	HC-040	Nylon Washer (Filter Inlet)
21-51	HCC-003A	Complete Control Box Assembly

(Please visit www.hydrotekintl.com to view our most current Products Pricing Sheet)